



快特電子股份有限公司

Quictron Corporation

115 台北市區南港區成功路一段32號4樓之10

Rm. 10, 4F., No.32, Sec. 1, Chenggong Rd., Nangang Dist., Taipei City 115, Taiwan, R.O.C

Tel : +886-2-2788-6849 Fax : +886-2-2788-7949

## APPROVAL SHEET

<b>Customer</b> 客 戶	
<b>Description</b> 零 件 概 述	24PIN, 10G BASE-T LAN Transformer,
<b>Customer's Part No.</b> 客 戶 料 號	
<b>Vendor's Part No.</b> 供 應 商 料 號	KM24SG0A1 G

<b>SUPPLIED BY</b>	<b>APPROVED BY</b>
蔣利敏	黃永華 Johnny Huang





## A. MECHANICAL(unit:mm)

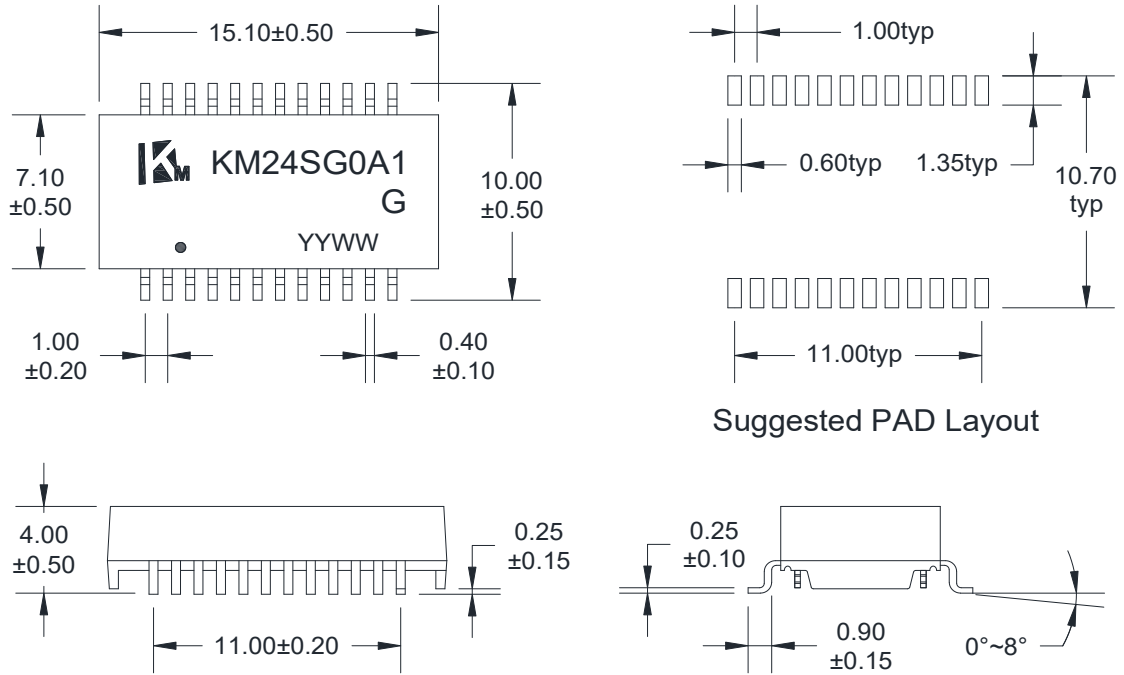

## B. SCHEMATICS

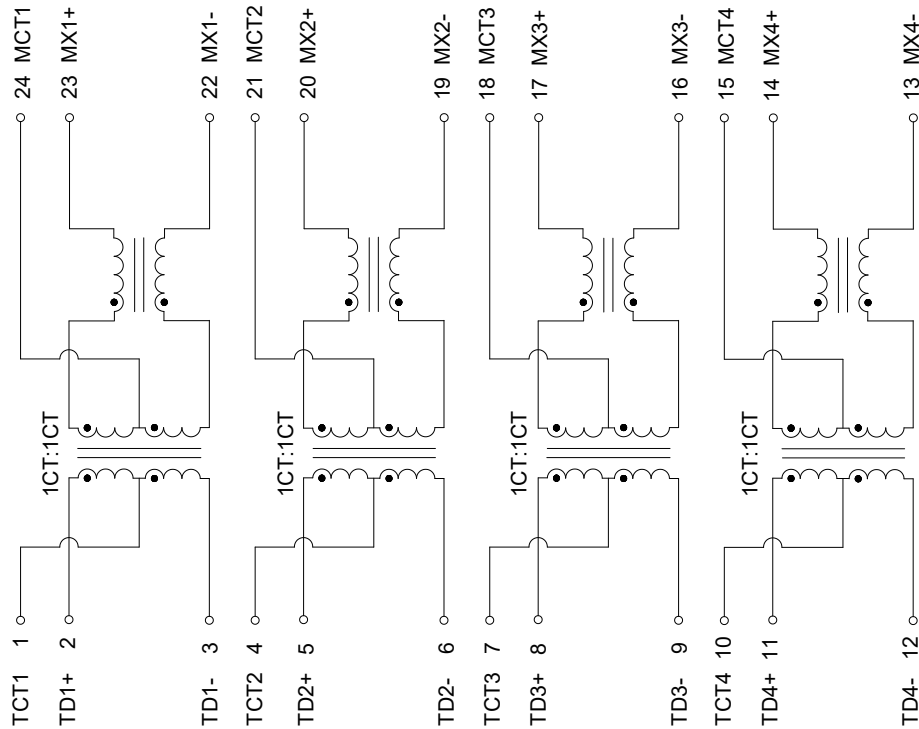

DESCRIPTION	KM P/N	SPEC NO	REV: R0
10G BASE-T	KM24SG0A1 G		PAGE: 2/4



## C. ELECTRICAL SPECIFICATIONS @25°C

1. OCL: 120uH Min @ 100 KHz, 0.1V
2. Leakage Inductance: 0.5uH Max @ 100KHz, 0.1V
3. DCR: 1000mΩ Max
4. Turns Ratio: 1CT:1CT±5%
5. Insertion Loss: -1.2 dB Max @ 1-200 MHz  
                           -1.5 dB Max @ 200-300 MHz  
                           -2.0dB Max @ 300-400 MHz  
                           -3.0dB Max @ 400-500 MHz
6. Return Loss: -18 dB Min @ 1-100 MHz  
                           -16 dB Min @ 100-200 MHz  
                           -12 dB Min @200-300 MHz  
                           -10 dB Min @ 300-400 MHz  
                           -8 dB Min @ 400-500 MHz
7. Cross Talk: -25 dB Typ Min @ 1-500 MHz
8. Common Mode Rejection: -25 dBTyp Min @ 1-500 MHz
9. Isolation Hipot: 1500VAC 1mA 60S
10. Operating temperature 0°C to +70°C
11. Storage temperature -20°C to +125°C
12. MSL: Grade: 1 Level. Floor life: 1 year Condition:<math>\leq 30^{\circ}\text{C}/60\%RH</math>

DESCRIPTION	KM P/N	SPEC NO	REV: R0
10G BASE-T	KM24SG0A1 G		PAGE: 3/4



## D. PACKAGE INFORMATION

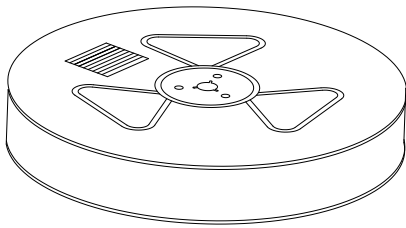
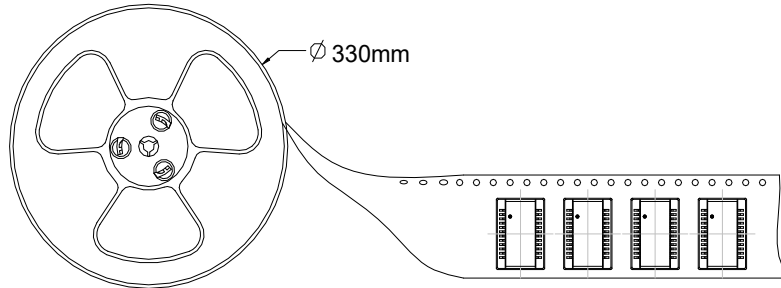
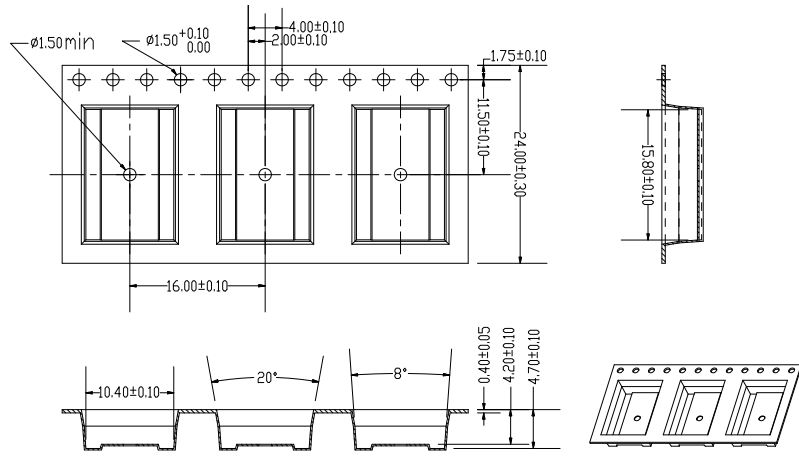

Three Reel

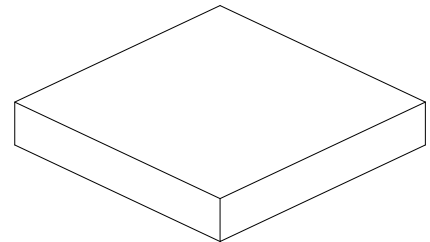

Inner Carton

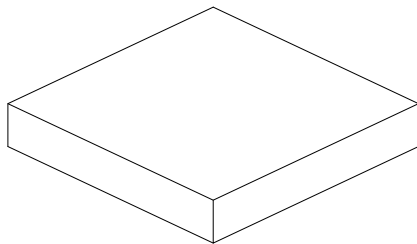

Two Inner Carton

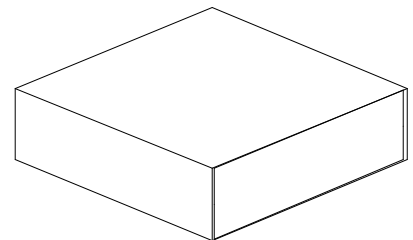

Export Carton

**Package Quantity:**

One Reel=800Pcs

One Inner Carton=800\*3=2400Pcs

One Export Carton=2400\*2=4800Pcs

DESCRIPTION	KM P/N	SPEC NO	REV: R0
10G BASE-T	KM24SG0A1 G		PAGE: 4/4