



快特電子股份有限公司

Quictron Corporation

115 台北市區南港區成功路一段32號4樓之10
Rm. 10, 4F., No.32, Sec. 1, Chenggong Rd., Nangang Dist., Taipei City 115, Taiwan, R.O.C
Tel : +886-2-2788-6849 Fax : +886-2-2788-7949

APPROVAL SHEET

Customer 客 戶	
Description 零 件 概 述	24PIN, 2.5G BASE-T LAN Transformer, KM24SG782 G
Customer's Part No. 客 戶 料 號	
Vendor's Part No. 供 應 商 料 號	KM24SG782 G

SUPPLIED BY	APPROVED BY
蒋利敏	黃永華 Johnny Huang

APPROVED SHEET

CUSTOMER: _____

KM P/N: _____

KM24SG782 G

P/N: _____

REV: _____

R0

DESCRIPTION: _____

2.5G BASE-T

CUSTOMER APPROVAL		COMPANY APPROVAL	
INSPECTED BY:		ISSUED BY:	蒋利敏
CHECKED BY:		CHECKED BY:	
APPROVED BY:		APPROVED BY:	
APPROVED DATE:		ISSUED DATE:	2020-3-4

Please Return One Copy to Us After Approved,TKS! (承认后请回寄一份,谢谢)



A. MECHANICAL(unit:mm)

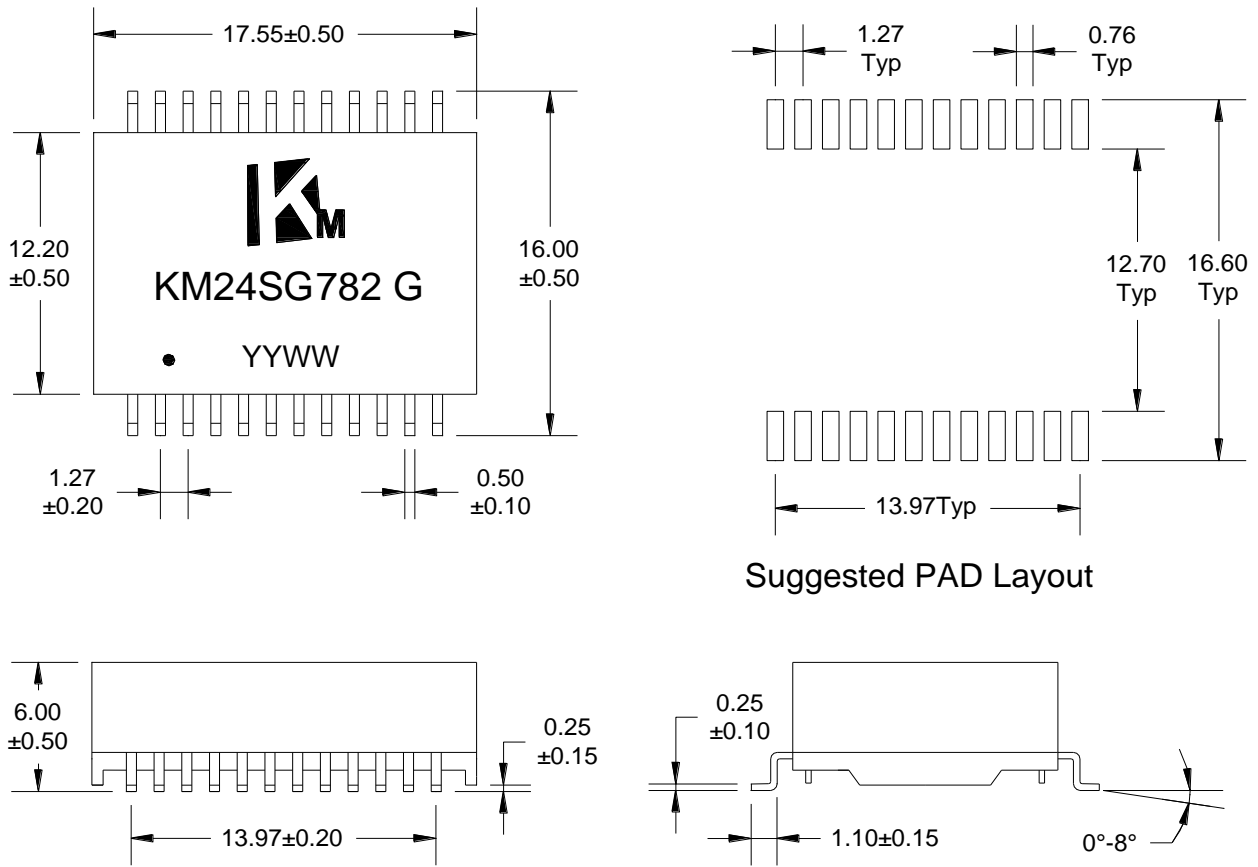

B. SCHEMATICS

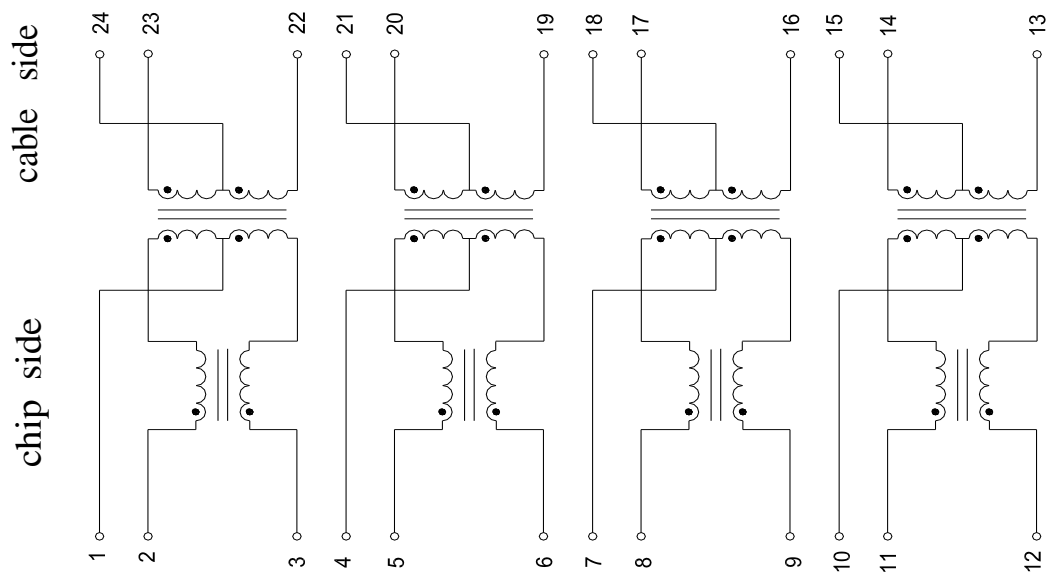

DESCRIPTION	KM P/N	SPEC NO.	REV: R0
2.5G BASE-T	KM24SG782 G		PAGE: 1/3



C. ELECTRICAL SPECIFICATIONS @25°C

1. OCL: 180uH Min @ 100 KHz, 0.1V,8mA DC Bias
2. Leakage Inductance: 0.5uH Max @ 100KHz, 0.1V
3. DCR: 1.0Ω Max
4. Turns Ratio: 1CT:1CT±5%
5. Insertion Loss: -1.0 dB Max @ 1-100 MHz
-2.0 dB Max @ 100-250 MHz
6. Return Loss: -16 dB Min @ $1 \leq f \leq 40$ MHz
- $16+10\log_{10}(f/40)$ dB Min @ $40 < f \leq 250$ MHz, where f is in MHz
7. Cross Talk: -30 dB Min @ 1-150MHz
8. Common Mode Rejection: -30 dB Min @ 1-150 MHz
9. Isolation Hipot: 1500VAC 1mA 60S
10. Operating temperature 0°C to +70°C
11. Storage temperature -25°C to +125°C
12. MSL: Grade: 1 Level. Floor life: 1 year Condition: $\leq 30^{\circ}\text{C}/60\% \text{RH}$

DESCRIPTION	KM P/N	SPEC NO.	REV: R0
2.5G BASE-T	KM24SG782 G		PAGE: 2/3



D. PACKAGE INFORMATION

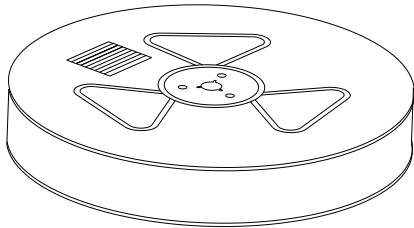
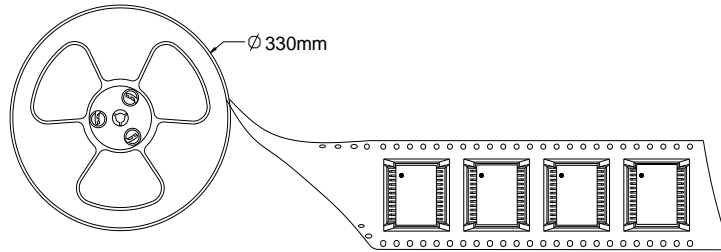
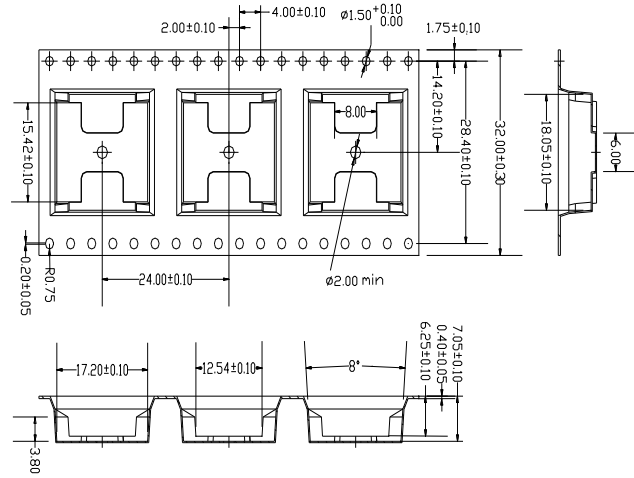

two reel

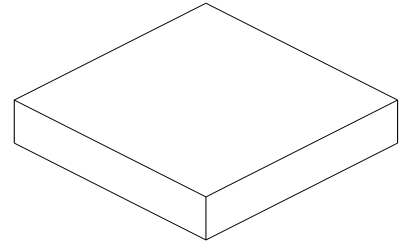

Inner Carton

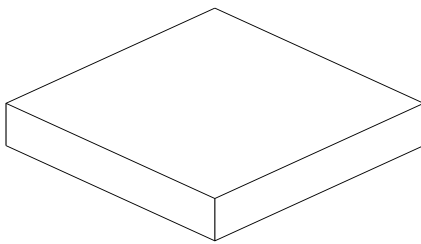

five Inner Carton

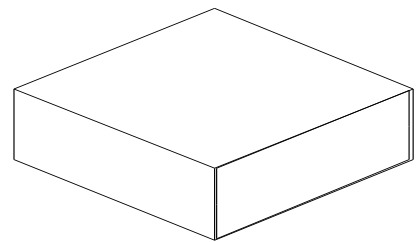

Export Carton

Package Quantity:

One Reel=350Pcs

One Inner Carton=350*2=700Pcs

One Export Carton=700*5=3500Pcs

DESCRIPTION	KM P/N	SPEC NO.	REV: R0
2.5G BASE-T	KM24SG782 G		PAGE: 3/3