



快特電子股份有限公司

Quictron Corporation

115 台北市區南港區成功路一段32號4樓之10

Rm. 10, 4F., No.32, Sec. 1, Chenggong Rd., Nangang Dist., Taipei City 115, Taiwan, R.O.C

Tel : +886-2-2788-6849 Fax : +886-2-2788-7949

## APPROVAL SHEET

<b>Customer</b> 客 戶	
<b>Description</b> 零 件 概 述	24PIN, 5G BASE-T LAN Transformer, KM24SG091 G
<b>Customer's Part No.</b> 客 戶 料 號	
<b>Vendor's Part No.</b> 供 應 商 料 號	KM24SG091 G

<b>SUPPLIED BY</b>	<b>APPROVED BY</b>
蔣利敏	黃永華 Johnny Huang

## A. MECHANICAL(unit:mm)

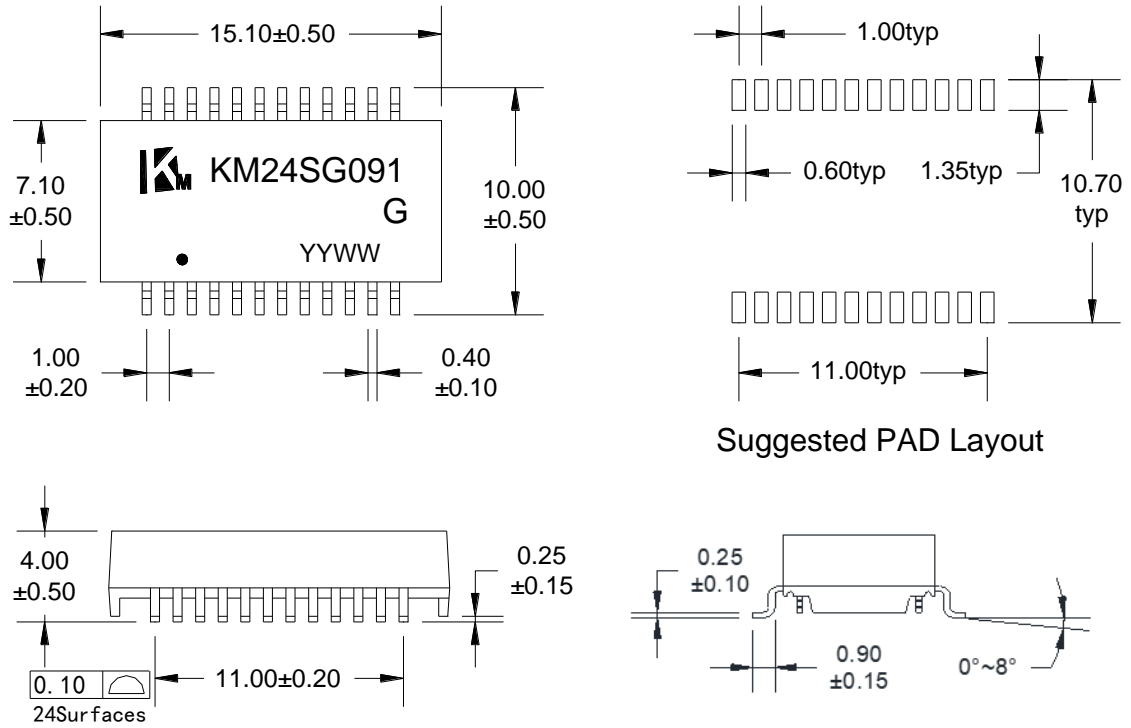

## B. SCHEMATICS

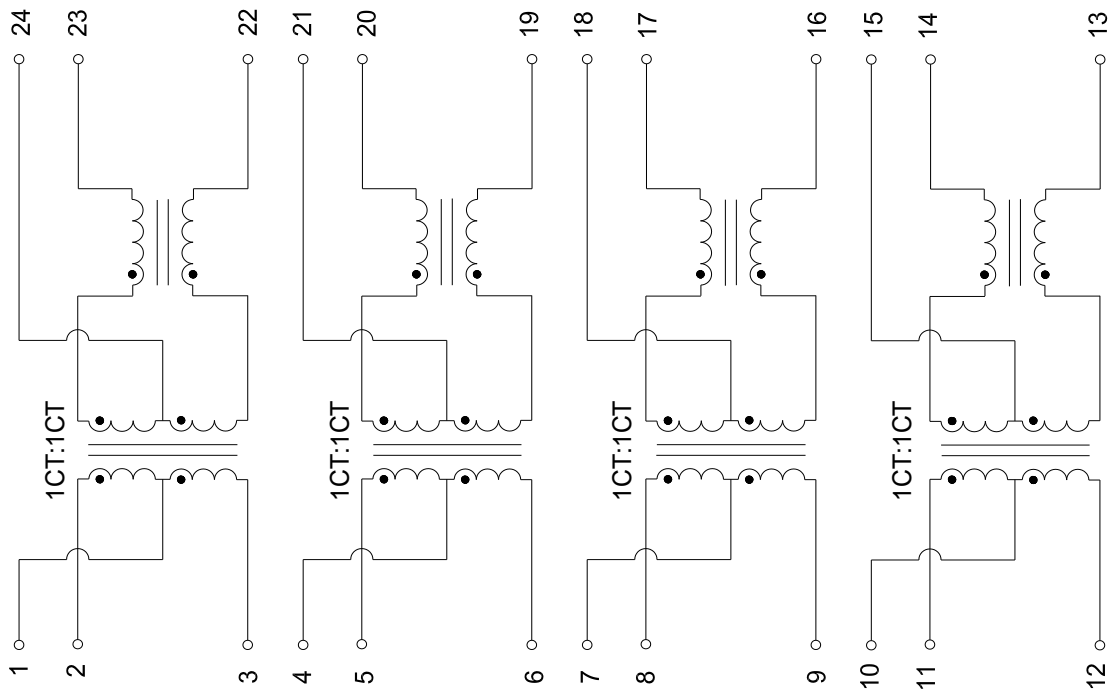

DESCRIPTION	KM P/N	SPEC NO.	REV: R0
5G BASE-T	KM24SG091 G		PAGE: 1/3

**C. ELECTRICAL SPECIFICATIONS @25 °C**

1. OCL: 160uH Min @ 100 KHz, 0.1V , 8mA DC Bias
2. Leakage Inductance: 0.5uH Max @ 100KHz, 0.1V
3. DCR: 1.0Ω Max
4. Turns Ratio: 1CT:1CT±5%
5. Insertion Loss: -1 dB Max @ 1-100 MHz  
-2.0 dB Max @ 100-250 MHz
6. Return Loss: -16 dB Min @  $1 \leq f \leq 40$  MHz  
-16+10log(f/40) dB Min @  $40 < f \leq 250$  MHz ,where f is in MHz
7. Cross Talk: -30 dB Min @ 1-250MHz
8. Common Mode Rejection: -30 dB Min @ 1-250 MHz
9. Isolation Hipot: 1500VAC 1mA 60s
10. Operating temperature 0 °C to +70 °C
11. Storage temperature -25 °C to +125 °C
12. MSL: Grade: 1Level. Floor life: 1year Condition:  $< / = 30^{\circ}\text{C} / 60\% \text{RH}$

DESCRIPTION	KM P/N	SPEC NO.	REV: R0
5G BASE-T	KM24SG091 G		PAGE: 2/3

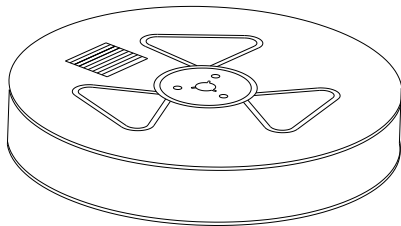
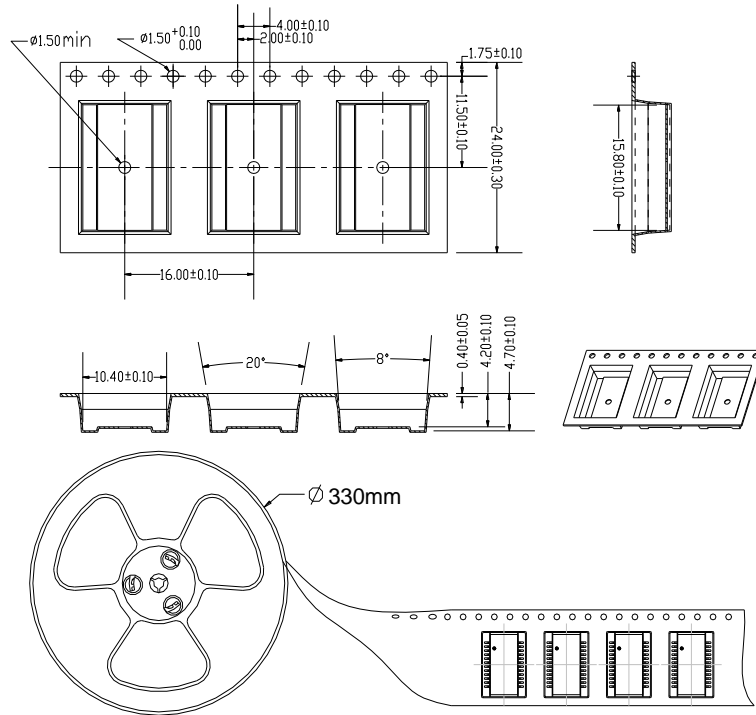
**D. PACKAGE INFORMATION**

three reel

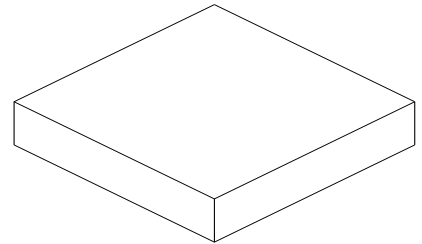

Inner Carton

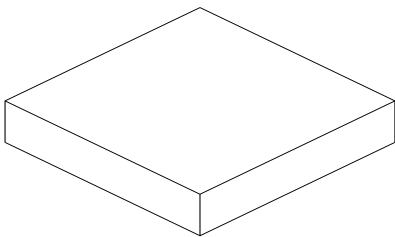

two Inner Carton

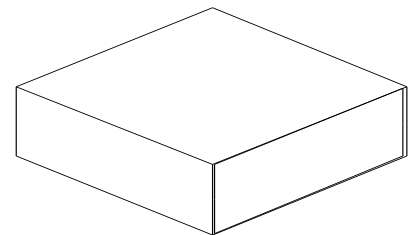

Export Carton

**Package Quantity:**

One Reel=800Pcs

One Inner Carton=800\*3=2400Pcs

One Export Carton=2400\*2=4800Pcs

DESCRIPTION	KM P/N	SPEC NO.	REV: R0
5G BASE-T	KM24SG091 G		PAGE: 3/3