

# APPROVED SHEET

CUSTOMER: 快特

KM P/N: KM48SG082-1P G

JWD P/N: SQ48004P G

REV: R0

DESCRIPTION: 2.5/5G BASE-T

---

---

---

---

CUSTOMER APPROVAL		COMPANY APPROVAL	
INSPECTED BY:		ISSUED BY:	Sea
CHECKED BY:		CHECKED BY:	
APPROVED BY:		APPROVED BY:	
APPROVED DATE:		ISSUED DATE:	2019-10-22

Please Return One Copy to Us After Approved,TKS! (承认后请回寄一份,谢谢)



## A. MECHANICAL (unit:mm)

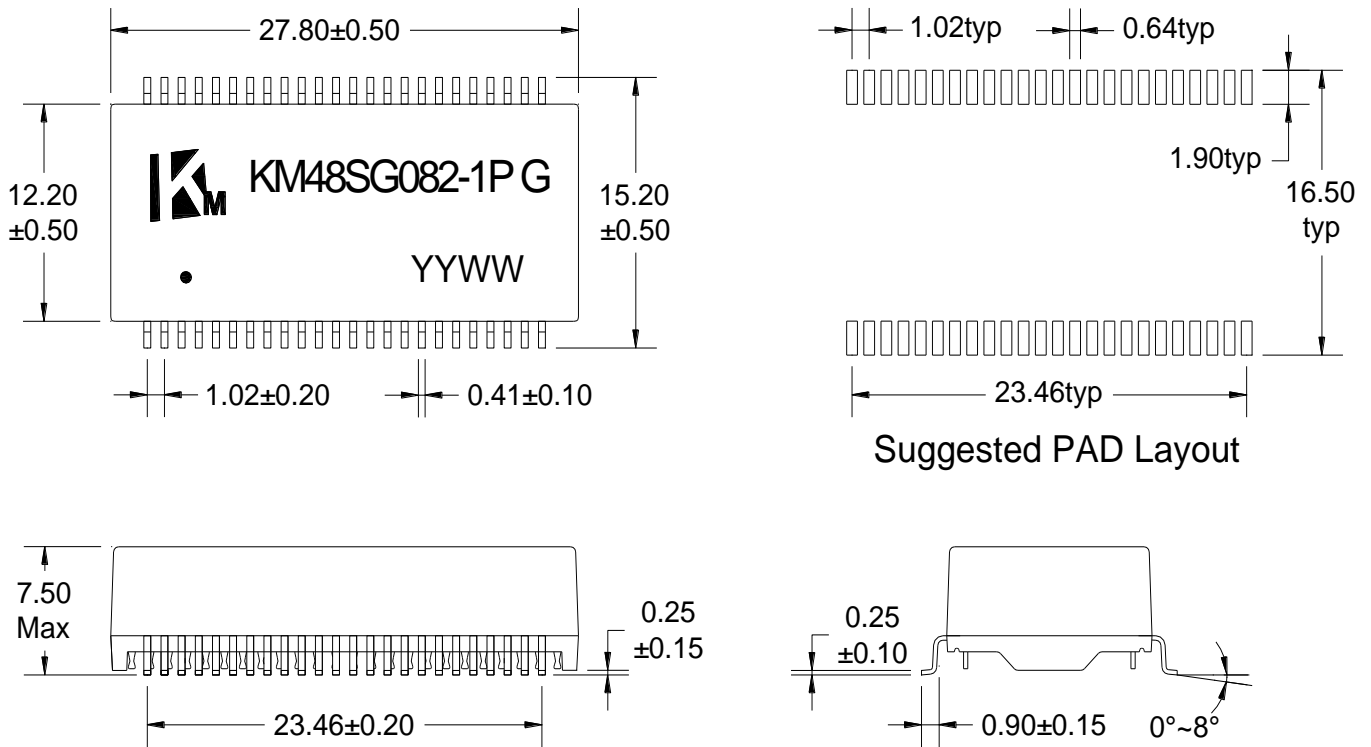

## B. SCHEMATICS

### Cable Side

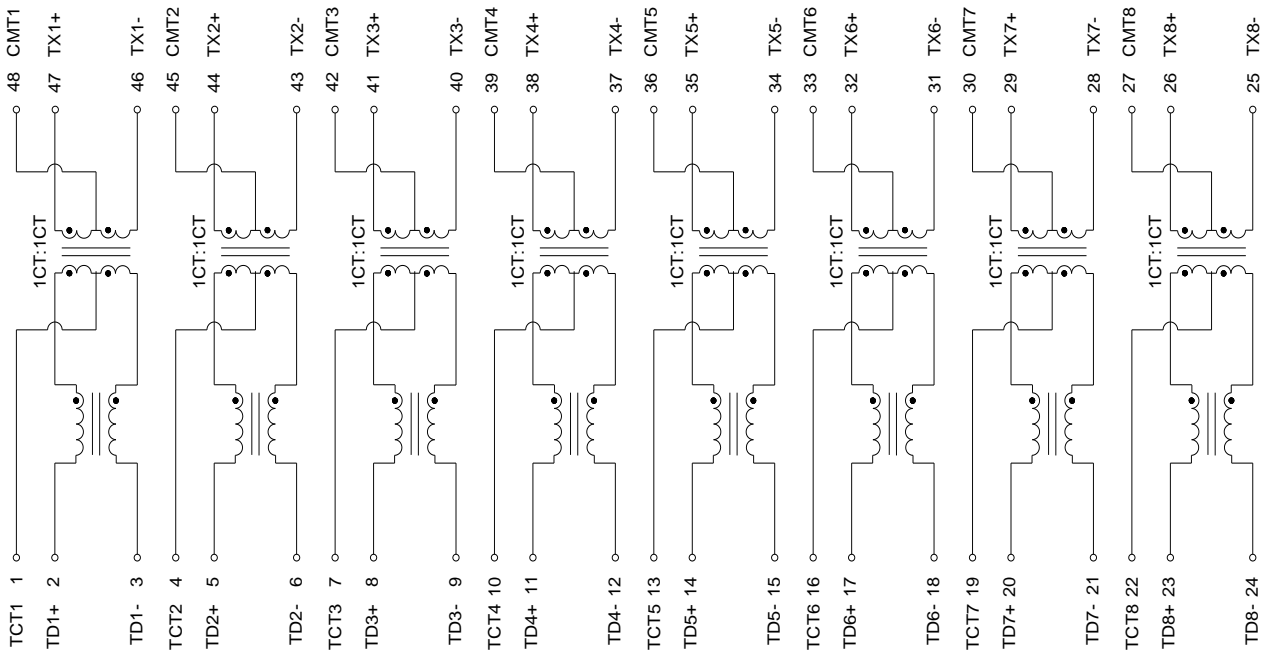

### Chip Side

DESCRIPTION	KM P/N	SPEC NO.	REV: R0
2.5/5G BASE-T	KM48SG082-1P G		PAGE: 1/3



## C. ELECTRICAL SPECIFICATIONS @25°C

1. OCL: 200uH Min @ 100KHz 0.1V with 8mA DC BIAS
2. Leakage Inductance: 0.5uH Max @ 100KHz, 0.1V
3. DCR: 1000mΩ Max
4. Turns Ratio: 1CT:1CT±5%
5. Insertion Loss: -1.0 dB Max @ 1-100 MHz  
-2.0 dB Max @ 100-250 MHz
6. Return Loss: -16 dB Min @  $1 \leq f \leq 40$  MHz  
-16+10log(f/40) dB Min @  $40 < f \leq 250$  MHz, where f is in MHz
7. Cross Talk: -30 dB Typ @ 1-250 MHz
8. Common Mode Rejection Ratio: -30 dB Typ @ 1-250 MHz
9. Isolation Hipot: 1500VAC 1mA 60S
10. Operating temperature 0°C to +70°C
11. Storage temperature -25°C to +125°C
12. PoE Support 15W: Each channel support 350mA DC balance current

DESCRIPTION	KM P/N	SPEC NO.	REV: R0
2.5/5G BASE-T	KM48SG082-1P G		PAGE: 2/3



## D. PACKAGE INFORMATION

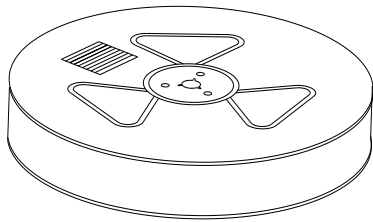
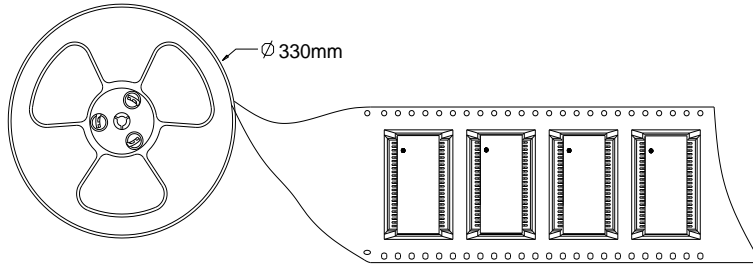
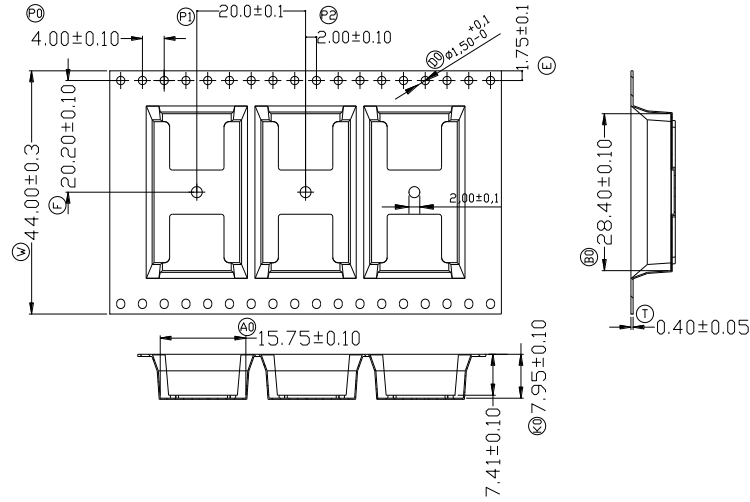

Two reel

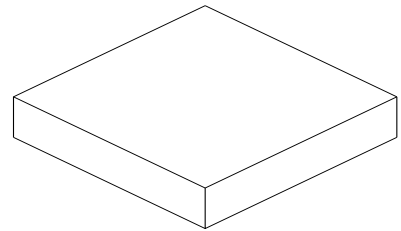

Inner Carton

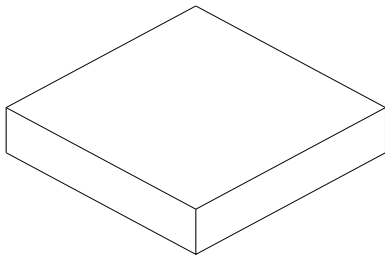

Two Inner Carton

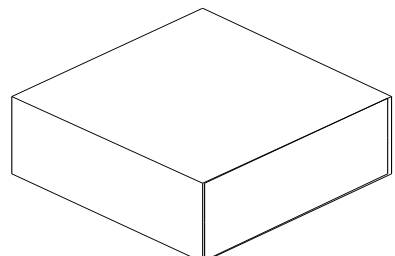

Export Carton

Package Quantity:

One Reel=350Pcs

One Inner Carton=350\*2=700Pcs

One Export Carton=700\*2=1400Pcs

DESCRIPTION	KM P/N	SPEC NO.	REV: R0
2.5/5G BASE-T	KM48SG082-1P G		PAGE: 3/3